

► Overview

Thermowells are recommended for temperature instruments in process systems where pressure, velocity, or viscous, abrasive, and corrosive materials are present individually or in combination. A properly selected thermowell will protect the temperature instrument from damage resulting from these process variables.

Additionally, a thermowell enables removal of the temperature instrument for replacement, repair, or testing without affecting the process system. We stock a wide range of popular industry thermowells to suit industrial & bi-metal thermometers, thermocouples, RTD's & temperature recorders.

We welcome special inquiries on thermowells, please contact our sales desk.

► Specifications

Type	.260 Bore Standard Stepped .702 Bore Straight
Instrument Connection	1/2" FNPT
Process Connection	1/2" MNPT 3/4" MNPT 1" MNPT
Materials	316SS
Stem Lengths	2.5" 4" 6" 9" 12"

► Ordering & Dimensions

.702 Bore Testwell - Standard Straight									
Process Connection "P"	Model Number	Stem Length "L"		Insertion Length "U"		"B" Diameter		Overall Length	
		in	mm	in	mm	in	mm	in	mm
3/4" NPT	76210200	3.75	95	2	51	.825	21	4	102
	76210400	4.75	120	3	76	.825	21	5	127
	76210600	5.75	146	4	102	.825	21	6	152
1" NPT	78210200	3.75	95	2	51	1	25	4	102
	78210400	4.75	120	3	76	1	25	5	127
	78210600	5.75	146	4	102	1	25	6	152

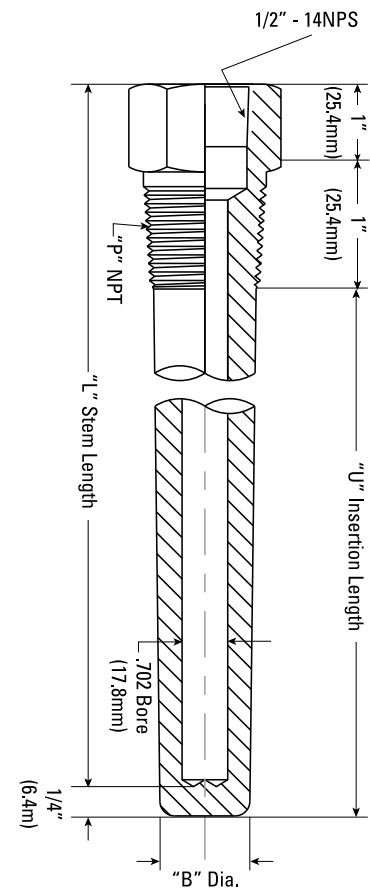

Drawing is not to scale.

► Ordering & Dimensions

.260 Bore Thermowells - Standard Stepped									
Process Connection "P"	Model Number	Stem Length "L"		Insertion Length "U"		"B" Diameter		Overall Length	
		in	mm	in	mm	in	mm	in	mm
1/2" - 14 - NPT In Stock	S12-025-316	2.5	64	1.25	32	-	-	2.75	70
	S12-040-316	4.0	102	2.5	64	-	-	4.25	108
	S12-060-316	6.0	152	4.5	114	0.63	16	6.25	159
	S12-090-316	9.0	229	7.5	191	0.63	16	9.25	235
	S12-120-316	12.0	305	10.5	267	0.63	16	12.25	311
3/4" - 14 - NPT In Stock	S34-025-316	2.5	64	1.25	32	-	-	2.75	70
	S34-040-316	4.0	102	2.5	64	-	-	4.25	108
	S34-060-316	6.0	152	4.5	114	0.75	19	6.25	159
	S34-090-316	9.0	229	7.5	191	0.75	19	9.25	235
	S34-120-316	12.0	305	10.5	267	0.75	19	12.25	311
1" - 11.5 - NPT	S10-025-316	2.5	64	1.25	32	-	-	2.75	70
	S10-040-316	4.0	102	2.5	64	-	-	4.25	108
	S10-060-316	6.0	152	4.5	114	0.83	22	6.25	159
	S10-090-316	9.0	229	7.5	191	0.83	22	9.25	235
	S10-120-316	12.0	305	10.5	267	0.83	22	12.25	311

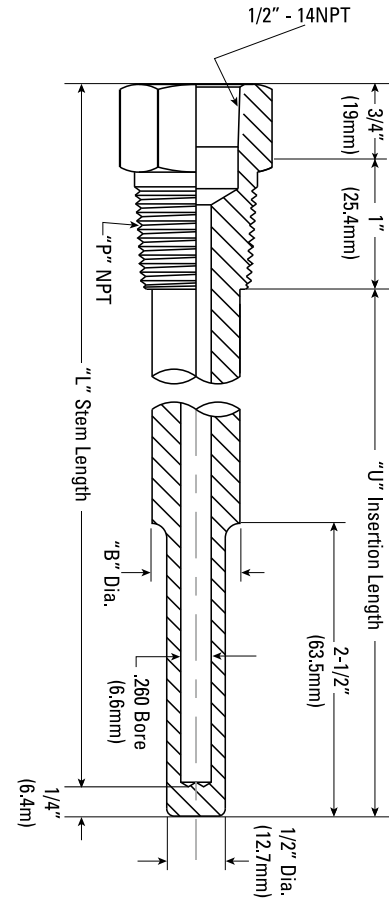

Drawing is not to scale.

Pressure - Temperature Rating - PSI

Material	Temperature (° Celcius)						
	20	95	205	315	425	540	650
Brass	5000	1200	1000	-	-	-	-
304SS	7000	6200	5600	5400	5200	4500	1650
316SS	7000	7000	6400	6200	6100	5100	2500
Carbon Steel	5200	5000	4800	4600	3500	1500	-
Monel	6500	6000	5400	5300	5200	1500	-