

## GTLP Series (4"/100mm)

All Stainless Steel Capsule Gauges  
1/2"NPT Bottom Mount Standard



### ► Applications

Chemical and petrochemical industries, conventional and nuclear power plants, pumps, hydro-cleaning machines, presses, engine compressors, turbines, diesel engines and refrigerating plants, food and beverage, pharmaceutical industries.

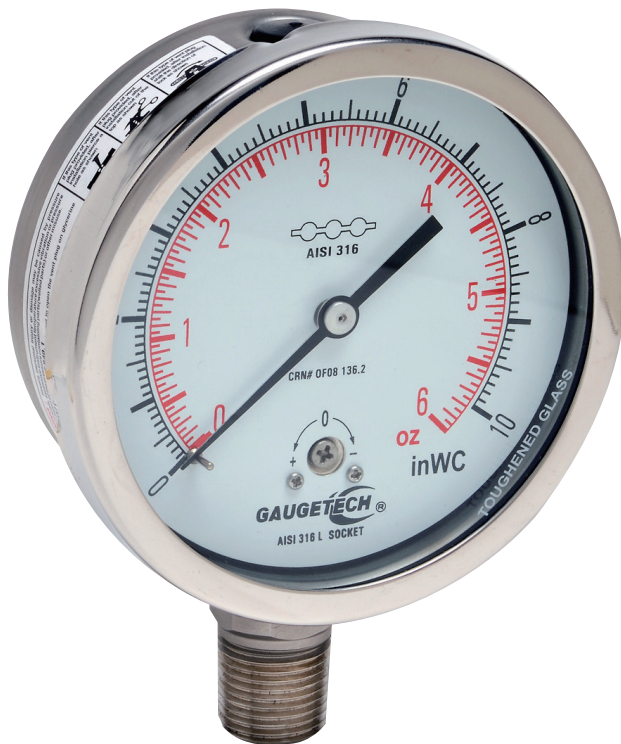

### ► Specifications

Accuracy	±1.0% of full scale ASME B40.1 Grade 1A
Ambient temperature	-40°C to +65°C
Process temperature	Max 150°C (Dry)
Operating pressure	75% of the scale value
Over pressure limit	110% of full scale value
Case	AISI 304 SS
Ring	AISI 304 SS, bayonet type
Capsule	AISI 316 SS
Socket	AISI 316L SS (directly welded to case)
Movement	AISI 304 SS
Welding	Tig argon arc welding
Protection	IP 65
Dial	Aluminum, black & red graduation on white background
Pointer	Aluminum, black colored micrometer zero adjustable
Window	Plexiglas Toughened Glass
Gaskets/Vent/Blow Out Plugs	Neoprene
Standard Scale	see ranges
Connection	1/2" NPT (standard) 1/4" NPT (optional)

### ► How to order

Part Number	Range	Part Number	Range
GTLP-410	-5"-0-5" wc / -2.8-0-2.8 oz	GTLP-434	0-5 psi / 0-35 kPa
GTLP-430	0-10" wc / 0-6 oz	GTLP-437	0-25" wc / 0-14 oz
GTLP-431	0-15" wc / 0-9 oz	GTLP-439	0-100" wc/0-60 oz
GTLP-432	0-40" wc / 0-23 oz	GTLP-440	-20"-0-20" wc / -11.5-0-11.5 oz
GTLP-433	0-60" wc / 0-35 oz	GTLP-460	-30"-0-30" wc / -18-0-18 oz

Typically stocked in our warehouse. Other ranges available. Contact Gaugetech for details.

# GTLP Series (4"/100mm)

All Stainless Steel Capsule Gauges  
1/2" NPT Bottom Mount Standard



## ► Dimensions (Drawings are not to scale. Dimensions in millimeters.)

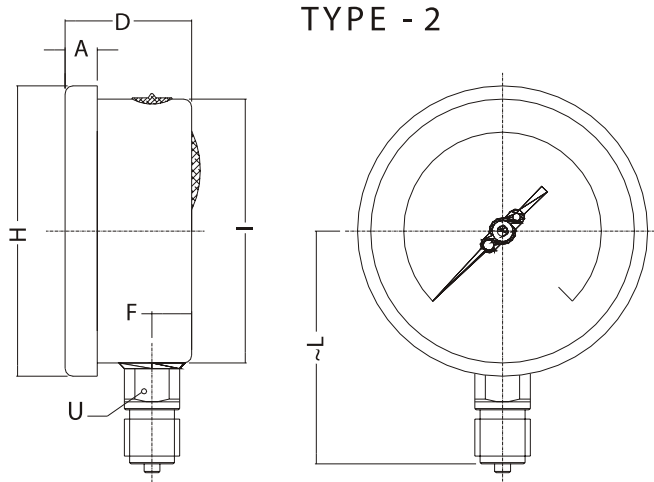

NS	A	D	F	H	I	~L	U	WT(kg)
100	12	47	16.5	110.5	100	90	22	0.64