

Differential Pressure Indicators

Piston Style



► Applications

These piston instruments can indicate small values of differential pressure even when used at high line pressures. They provide instantaneous and continuous information regarding system conditions helping in eliminating premature servicing of equipment, avoid unscheduled down time of costly processes and detect abnormal system conditions.

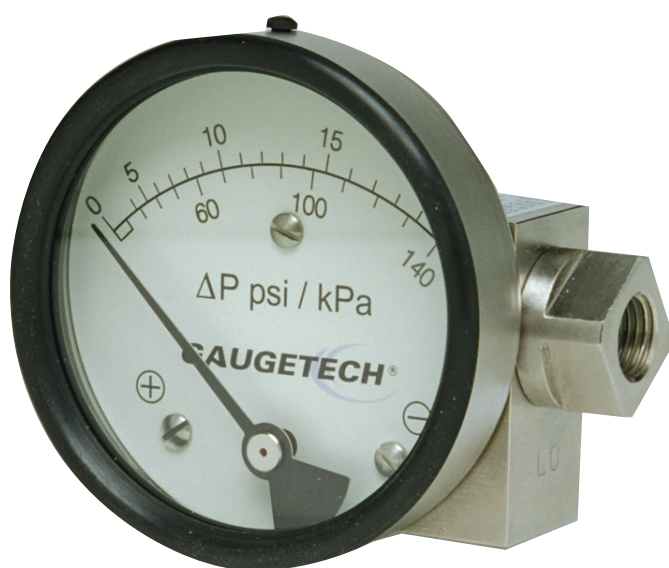

► Specifications

Ranges	0-8, 0-20, 0-30, 0-50 0-100 psiD/kPa, from stock Others available (on request)
Max temperature	175°F / 80°C
Max Pressure	3000 psi Aluminum 6000 psi 316SS
Standard Ranges	0-5 psiD to 0-150 psiD
Wetted Materials	Aluminum or stainless steel
Seals	Buna-N or Viton®
Migration of Media	Minor
Accuracy	FSD Ascending +/-2%
Dial Size	3.5" Others available (on request)
Case	Stainless steel, weatherproof or stainless steel flanged, weatherproof
Connection	1/4" FNPT (standard) others available (on request)
Line Connection Location	In-line (standard) Back or bottom (on request)

► How to order

Dial Size	3.5" (in stock)	3.5" (in stock)
Case	Stainless steel	Stainless steel
Wetted Parts	Aluminum	Stainless steel
Seals	Buna-N	Viton®
Mounting	In-line	In-line
Connection	1/4" FNPT	1/4" FNPT
Ranges (in stock):		
0-8 psiD/kPaD	GTDPGA350-8PSID	GTDPGSS350-8PSID
0-20 psiD/kPaD	GTDPGA350-20PSID	GTDPGSS350-20PSID
0-30 psiD/kPaD	GTDPGA350-30PSID	GTDPGSS350-30PSID
0-50 psiD/kPaD	GTDPGA350-50PSID	GTDPGSS350-50PSID
0-100 psiD/kPaD	GTDPGA350-100PSID	GTDPGSS350-100PSID

Other ranges available. Contact Gaugetech for details.

Differential Pressure Indicators

Piston Style



► Dimensions (Drawings are not to scale. Dimensions in millimeters.)

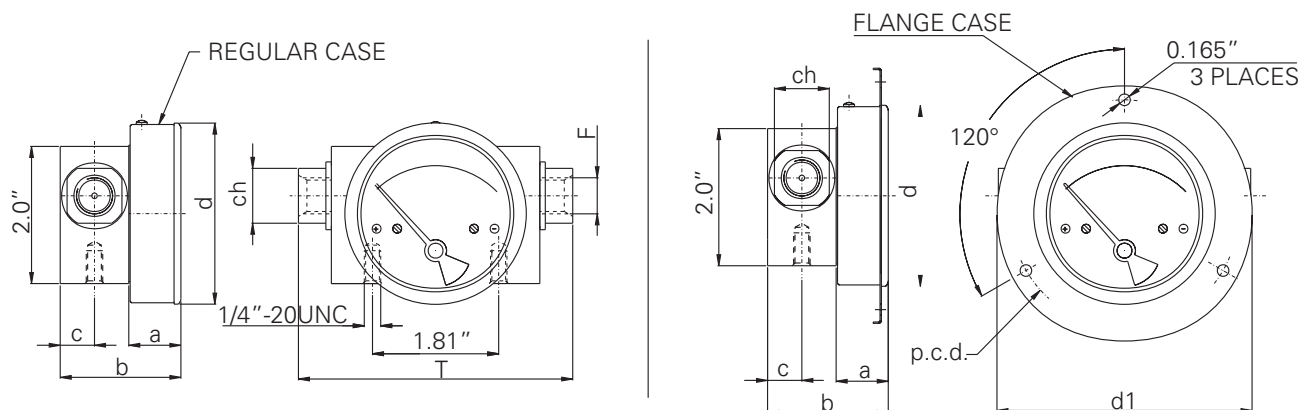

DN	F	a	b	c	d*	d ₁	T	ch	p.c.d
2.0"	1/4" NPT	0.70"	1.70"	0.5"	2.08"	3.11"	4.0"	0.75" sq	2.72"
2.5"	1/4" NPT	0.75"	1.75"	0.5"	2.59"	3.66"	4.0"	0.75" sq	3.26"
3.5"	1/4" NPT	0.75"	1.75"	0.5"	3.26"	4.29"	4.0"	0.75" sq	3.89"
4.0"	1/4" NPT	0.75"	1.75"	0.5"	4.10"	5.15"	4.0"	0.75" sq	4.76"
4.5"	1/4" NPT	0.75"	1.75"	0.5"	4.71"	5.74"	4.0"	0.75" sq	5.35"
6.0"	1/4" NPT	0.75"	1.75"	0.5"	6.07"	7.12"	4.0"	0.75" sq	6.73"

*Panel cut out = d + 0.04"

Drawings are not to scale. Dimensions in millimeters.